

5 read-out options!

1:

Targets:
Aligned when laser hits both target slots

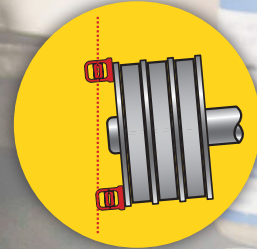

2:

Built-in display:
Offset (mm or inch)
Horizontal angle
Vertical angle



3:

iOS and Android:
Phones and tablets.
Free app available.



4:

E51 and E52 Display unit*:
Full graphic interface
with ability to document the result



5:

XT11 Display unit*:
Full graphic interface
with ability to document the result



* Display unit not included.

Fits almost any kind of sheave!



V-BELT

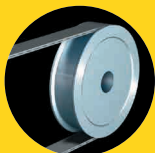

FLAT BELT



TIMING BELT



CHAIN DRIVES

Belt Alignment

XT190



EASY TO USE

Easy-Laser® BTA is attached in a few seconds magnetically, with the laser transmitter on one of the sheaves and the detector on the other. The program guides the user in mounting the units. The transmitter generates a laser plane parallel to the reference sheave. The detector reads the position in relation to the laser plane and provides a live digital display of offset and both angular values. This makes the alignment of the adjustable machine very simple. The accuracy of the digital readout lets you align within prescribed tolerances and rely on the result.

CONNECT TO A DISPLAY UNIT

Using a separate display unit makes it all even easier, as you can read off and follow the adjustment at the precise point on the machine where the adjustment is made. You get adjustment values for both horizontal and vertical directions (shim value), resulting in a more accurate alignment in a shorter time. You can also save the results in the display unit's internal memory and produce a PDF report.

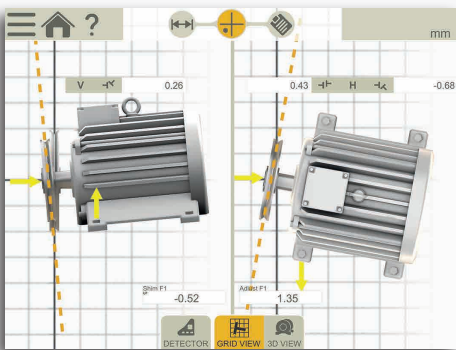

With the XT-series: Download the Easy-Laser XT Alignment App and use your phone or tablet as the display unit. Or use your XT11 display unit.*

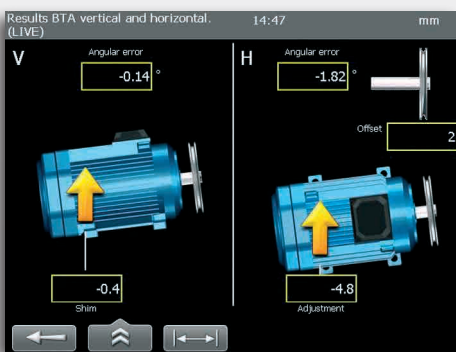

With the E-series: Display units E51 and E52 for the E-series shaft and geo systems have a pulley alignment program included. Add the XT190 and you can also document your belt alignments!

**Please see www.easylaser.com for compatible models.*

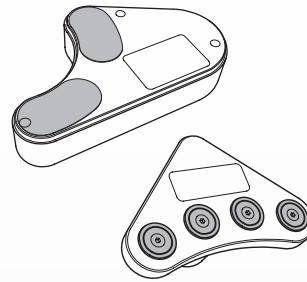

Magnetic reference surface on both transmitter and detector for easy attachment to the sheaves. On non-magnetic sheaves the units can be mounted with double-sided adhesive tape or with clamps.

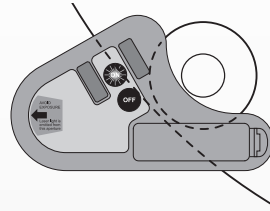

Thanks to the clever design the units fit small as well as large sheaves.

TECHNICAL DATA

Easy-Laser® XT190 BTA, Part No. 12-1053	
1	Laser transmitter
1	Detector
2	Targets
1	Charger (100–240 V AC) with cable
1	USB memory stick with documentation
1	Carrying case, WxHxD: 270x225x80 mm [10.6"x8.8"x3.1"]
Laser transmitter	
Sheave diameters	∅60 mm [2.5"] and larger
Laser class	2
Output power	<1 mW
Laser wavelength	635–670 nm
Beam angle	60°
Accuracy	Laser plane – Reference plane: Parallelity: < 0.05°, Offset < 0.2 mm [0.008"]
Battery type	1xR6 (AA) 1.5 V
Battery operation	8 hours continuously
Material	ABS plastics / Hard anodized aluminium
Dimensions	WxHxD: 145x86x30 mm [5.7x3.4x1.2"]
Weight	270 g [9.5 oz]
Detector unit	
Measurement distance	Up to 3 m [9.8'] between Transmitter and Detector
Measurement range	Axial offset: ±3 mm [0.12"]. Angular value: ±8°
Display type	Yellow OLED 96x96 pixels
Connection	Bluetooth® wireless technology
Battery type	Li-Po
Battery operation	5 hours continuously
Material	ABS plastics / Anodized aluminium
Dimensions	WxHxD: 95x95x36 mm [3.7x3.7x1.4"]
Weight	190 g [6.7 oz]

Download the free app!

Easy-Laser XT Alignment App



Easy-Laser® is manufactured by Easy-Laser AB, Alfagatan 6, SE-431 49 Mölndal, Sweden
Tel +46 31 708 63 00, Fax +46 31 708 63 50, e-mail: info@easylaser.com, www.easylaser.com
© 2017 Easy-Laser AB. We reserve the right to make changes without prior notification.

Easy-Laser® is a registered trademark of Easy-Laser AB. Android, Google Play, and the Google Play logo are trademarks of Google Inc. Apple, the Apple logo, iPhone, and iPod touch are trademarks of Apple Inc., registered in the U.S. and other countries. App Store is a service mark of Apple Inc. Other trademarks belong to their respective owners. This product complies with: EN60825-1, 21 CFR 1040.10 and 1040.11. Contains FCC ID: Q00BT121, IC: 5123A-BGTBT121. Documentation ID: 05-0866 Rev1



dB Vib Instrumentation

Montée de Malissol
38200 VIENNE

Tél. 04 74 16 18 80 – Fax 04 74 16 18 89
Siret 435 015 698 00028